

Description

S6-880Y440 series is specially designed for sports Lighting and industrial lighting applications. It is constant current LED driver that operates from 220-480Vac with DMX512/DALI-2 programming dimming function. This Rectangle integrated structure enables it to have a better heat dissipation cooler, significantly improving reliability and extending product life. To ensure trouble free operation, protection is provided against input surge, output over voltage, short circuit, and over temperature. The better thermal design and high efficiency enable the driver to operate with high reliability, and extending product lifetime. Overall protection is provided against lightning surge, output over voltage, short circuit, and over temperature, to ensure low failure rate.



Product Features

- Input voltage range: 198~528Vac;
- Constant current design;
- DMX -RDM control optional, Support RDM control mode & controller address setting;
- Support flashing function with maximum of 6 flashes per second;
- DALI-2 Dimming optional
- Non-Isolated Class I Driver;
- Efficiency up to 97%;
- Dim-to-off; No glow after Dim-to-off;
- DMX&DALI-2 control interface;
- Max remote distance 200 meters;
- Surge protection: 10KV line-line, 10KV line-earth @ 2Ω;
- Multiple protection: SCP, OVP, OTP;
- IP66, IK08 design for indoor and outdoor applications;
- 5 years warranty.

Application

Stadium lighting
Area and flood lighting
High-bay lighting

Models

Model Number	Input Voltage Range(Vac)	Max Output Power(W)	Output Voltage Range(Vdc)	Full Power Output Current	Default Current(A)	Eff.(Typ.)	PF(Typ.)	THD(Typ.)
S6-880Y440	198-528	880	190-440	2.00~3.60A	2.5A	96.5%	0.96	6%

NOTES:

[1].Y=D means DALI-2, Y=R means DMX-RDM.

[2].All specifications are measured at 25°C ambient temperature, input voltage 400Vac, and the typical value tested at full load, if no specific note.

Input Specifications

Parameter	Min	Typ.	Max	Notes
Input Voltage Typ.	220Vac	230/277/400/ 480Vac	480Vac	
Input Voltage Range	198Vac	-	528Vac	Refer to Output Power vs. Input Voltage curve
Input Frequency AC	47Hz	50/60Hz	63Hz	
Max Input Current	-	-	4.5A	220Vac&Full Load
Max Input Power	-	-	950W	220Vac&Full Load
Protective Conductor Current	-	-	3.5mA	220~480Vac/60Hz; IEC 60598-1;
Leakage Current	-	-	0.75mIU	UL8750
Inrush Current	-	0.8A ² S	1.0 A ² S	480Vac, full load,50%~50% peak pulse duration
Inrush Current	-	30A	35A	480Vac&Full Load, Cold Start
Standby Power Consumption	-	-	0.5W	230Vac&50Hz
Power Factor(PF)	0.97	0.99	-	220-277Vac, 50/60Hz, 100% Load
Power Factor(PF)	0.94	0.96	-	400Vac, 50/60Hz, 100% Load
Power Factor(PF)	0.92	0.94	-	480Vac, 50Hz, 100% Load
Power Factor(PF)	0.95	0.97	-	220-277Vac, 50/60Hz, 80% Load
Power Factor(PF)	0.93	0.95	-	400Vac, 50/60Hz, 80% Load
Power Factor(PF)	0.92	0.94	-	480Vac, 50Hz, 80% Load
Total Harmonic Distortion(THD)	-	6%	15%	220-480Vac, 50/60Hz, 100% Load
Total Harmonic Distortion(THD)	-	10%	20%	220-480Vac, 50/60Hz, 80%-100% Load
MCB(B16)	-	3	-	220Vac

Output Specifications

Parameter	Min	Typ.	Max	Notes
Output Voltage Range	190Vdc	-	440Vdc	The full power cannot be lower than 245Vdc
Open Circuit Voltage	-	-	530Vdc	
Output Current Range	5%I _{set}	-	100%I _{set}	Adjustable Output Current with programmer
Full Power Current Range	2.00A	-	3.60A	
Current Accuracy	-3%	-	+3%	
Total Output Current Ripple (pk-pk)	-	0.5%	1.0%	20MHz BW, full load& LED load, the ripple would be tiny different under different LED load.
Startup Overshoot Current	-	-	-	No overshoot.
Line Regulation	-2%	-	+2%	25°C±10°C ambient temperature, input voltage changes from 220Vac to 480Vac.
Load Regulation	-1%	-	+1%	25°C±10°C ambient temperature, Input Voltage 480Vac, load changes from 80% to 100%.
Turn-on Delay Time	-	-	1.5s	220~480Vac & 100% Load, load is LED

General Specifications

Parameter	Min	Typ.	Max	Notes
Efficiency@220Vac Io=2.00A	94.5%	96.0%	-	Measured at full load and 25°C ambient temperature
Efficiency@220Vac Io=3.60A	93.5%	95.0%	-	Measured at full load and 25°C ambient temperature
Efficiency@277Vac Io=2.00A	95.0%	96.5%	-	Measured at full load and 25°C ambient temperature
Efficiency@277Vac Io=3.60A	94.0%	95.5%	-	Measured at full load and 25°C ambient temperature
Efficiency@400Vac Io=2.00A	95.0%	96.5%	-	Measured at full load and 25°C ambient temperature
Efficiency@400Vac Io=3.60A	94.0%	95.5%	-	Measured at full load and 25°C ambient temperature
Efficiency@480Vac Io=2.00A	95.0%	96.5%	-	Measured at full load and 25°C ambient temperature
Efficiency@480Vac Io=3.60A	94.0%	95.5%	-	Measured at full load and 25°C ambient temperature
Mean Time Between Failure	-	200Khours	-	25°C±10°C ambient temperature, 220Vac, 80% load (MIL-HDBK-217F/SR-332)
Lifetime	-	50Khours	-	Ta=45°C, Tc=70°C, 220Vac&100% load
Ambient Temperature Ta	-40°C	-	+50°C	220Vac~480Vac&100% load,
Operating Tc for Safety Tc_s	-40°C	-	+85°C	
Operating Tc for Warranty Tc_w	-40°C	-	+70°C	5 years warranty case temperature Humidity: 10% to 80% RH No condensation
Storage Temperature Ta	-40°C	-	+85°C	
Altitude	-60m	-	4000m	
Input Under voltage Protection	150Vac	170Vac	190Vac	
External NTC (R1)	-	18K Ohm (Set by software)	-	When the R-NTC is reduced to R1, the external thermal protection is triggered and the output current gradually decreases.
External NTC (R2)	-	9.1K Ohm (Set by software)	-	When the R-NTC is reduced to R2, the output current is reduced to the programmed protection current value.
External NTC (Protection Circuit)	10%I _{oset}	60%I _{oset}	100%I _{oset}	10%I _{oset} >I _{omin} (Default setting 60%)
External NTC (Protection Circuit)	I _{omin}	60%I _{oset}	100%I _{oset}	10%I _{oset} ≤I _{omin} (Default setting 60%)
Over Temperature Protection Tc	-	85°C	-	Tc; 220Vac&100% load
Short Circuit Protection	-	-	-	self-recovery
Dimensions (L*W*H)	400*150*81mm			
Net Weight	4350±100g/PCS			
Package (L*W*H)	587*487*170mm; 2PCS/ctn, Gross Weight: 10.9Kg			

DMX Dimming

Parameter	Min	Typ.	Max	Notes
DMX+ to DMX-	-6V	-	6V	
DMX+ to Chassis	22M ohm	-	-	At 42Vdc
DMX- to Chassis	22M ohm	-	-	At 42Vdc
Logic 0 Input	-	-	-0.2V	DMX+ to DMX-
Logic 1 Input	0.2V	-	-	DMX+ to DMX-
Communication Baud Rate	-	250K bps	-	
Dimming Output Range	5% I_{omax}	-	100% I_{oset}	10% $I_{omax} \leq I_{oset} \leq 100\%I_{omax}$
Dimming value with turn off	-	-	1	5% I_{omax}
Dimming value with turn on	-	-	0	
flashing times per second	-	-	6	0%-100% I_{set}

Note:

All specifications are typical at 25°C.

DALI-2 Dimming(Optional)

Parameter	Min	Typ	Max	Notes
High Voltage Level	9.5V	16V	22.5V	
Lower Voltage Level	-6.5V	0V	6.5V	Return terminal is "DA-".
Dimming Output Range	5% I_{max}	-	100% I_{max}	$I_{max}=3.6A$.
Sink Current	-	-	2.0mA	
Timer dimming	-	-	-	Traditional, Self-adaption.
Output lumen compensation	-	-	-	Constant lumen output function.

Safety Specification

Parameter	CCC	CE/ENEC	UL	Notes
Dielectric Strength(Input-Ground)	2100Vac	2100Vac	2100Vac	60s , Current not exceeding 10mA
Dielectric Strength(Output-Ground)	2100Vac	2100Vac	2100Vac	60s , Current not exceeding 10mA
Dielectric Strength(Input-Dim)	4870Vac	4150Vac	2100Vac	60s , Current not exceeding 10mA
Grounding Resistance	0.1Ω(Max)			25°C±10°C Ambient Temperature, pass 25A Current, 60s.
Insulation Resistance	10MΩ(Min)			Input-PE, Output-PE, 500Vdc/60s/25°C/70%RH

Safety Compliance

Safety Category	Standards	Approved	Notes
CCC	GB19510.1,GB19510.14	√	
CE	EN61347-1, EN61347-2-13	√	
CE	EN62493	√	
ENEC	EN62384	√	
CB	IEC61347-1, IEC61347-2-13	√	
BIS	IS 15885(PART 2/SEC 13)		
UL	UL 8750		
CUL	CSA C22.2 No.250.13		
KC	K61347-1, K61347-2-13		
PSE	J61347-1, J61347-2-13		
SAA	AS/NZS IEC 61347.2.13		
SAA	AS/NZS 61347.1		

EMC Compliance

EMC Category	Standards	Approved	Notes
CCC	GB/T 17743, GB 17625.1	√	
CE	EN 55015	√	
CE	EN 61000-3-2, EN 61000-3-3	√	
CE	EN61000-4-2,3,4,5,6,11	√	
CE	EN 61547	√	
KC	K61547		
KC	K00015		
PSE	J55015		
FCC	FCC part 15		

RoHS

Our products comply with RoHS Directive (EU) 2015/863 amending Annex II to Directive 2011/65/EU.

Inrush Current

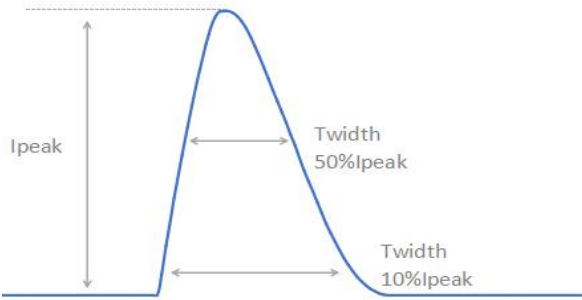

V_{in}	I_{peak}	$T(@10\% \text{ of } I_{peak})$	$T(@50\% \text{ of } I_{peak})$
480Vac	24.4A	2.79ms	1.33ms

Output Voltage vs. Output Current

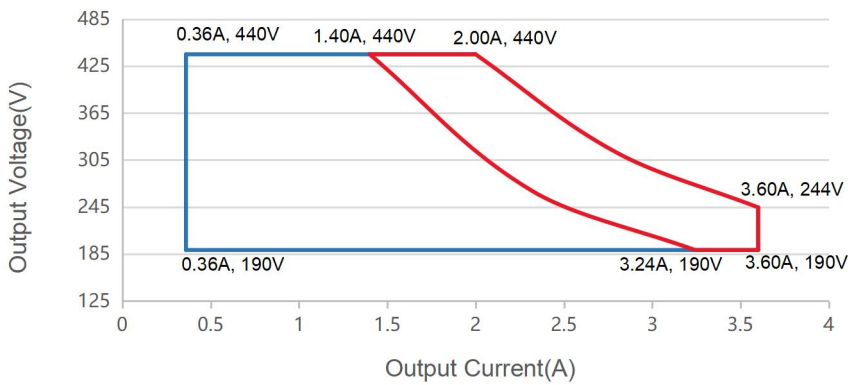

Red curve: good performance area

Output Power vs. Input Voltage

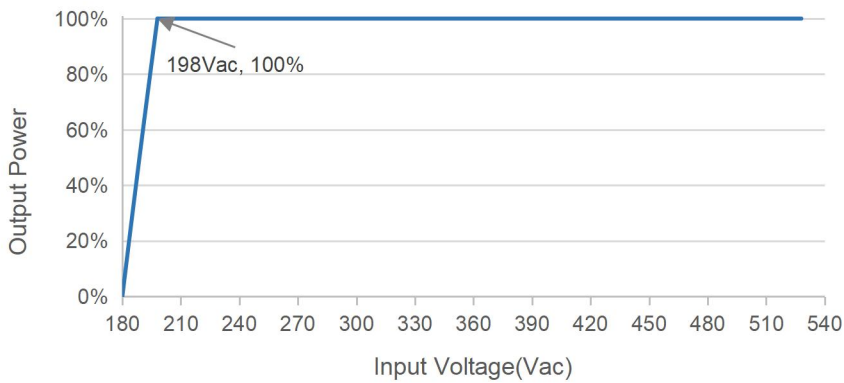

Efficiency vs. Load (Io=2.0A)

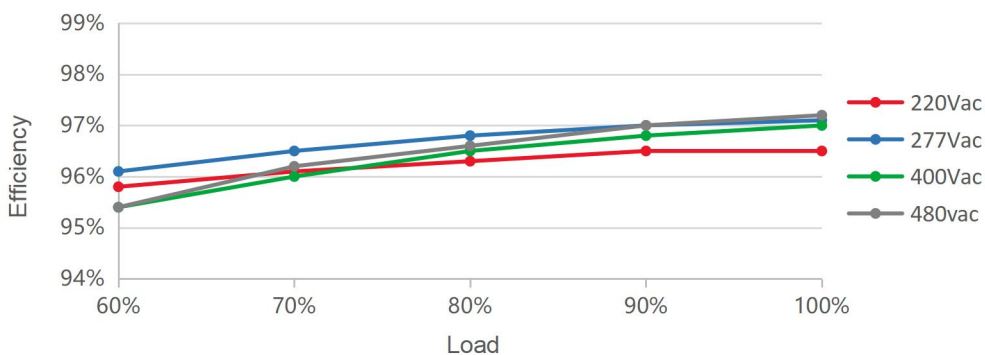

Efficiency vs. Load (I_o=3.6A)

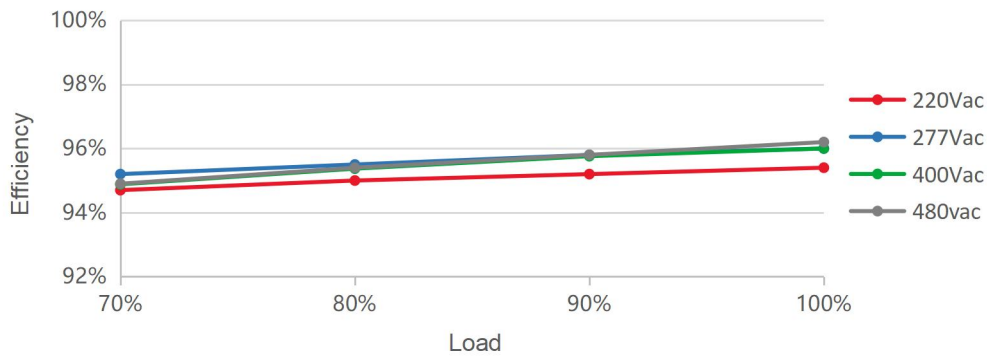

PF vs. Load

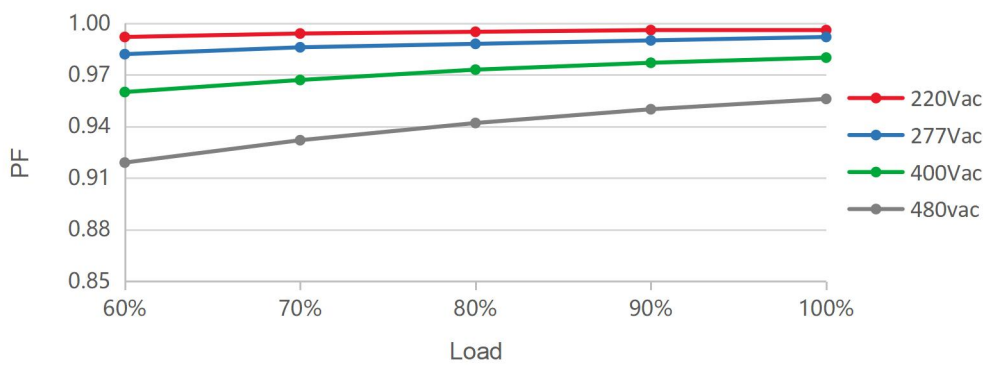

THD vs. Load

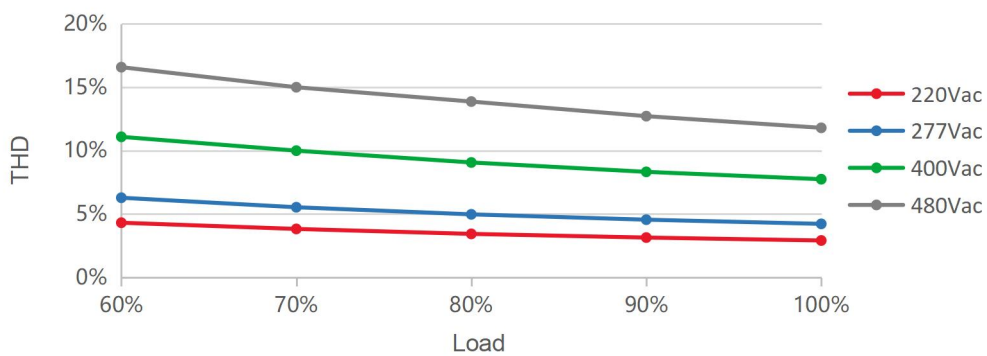

Output Power vs. Ambient Temperature

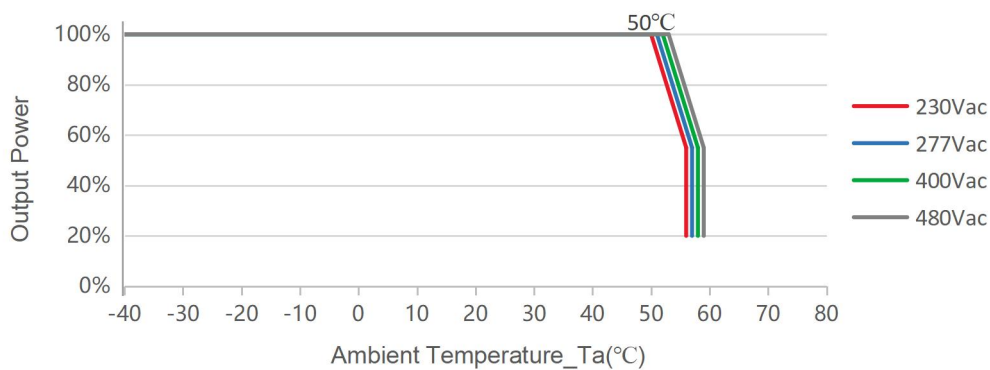

Lifetime vs. Case Temperature

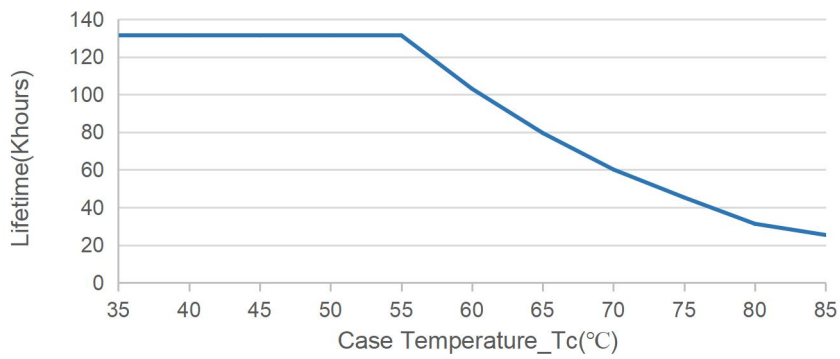

DMX Dimming Curve

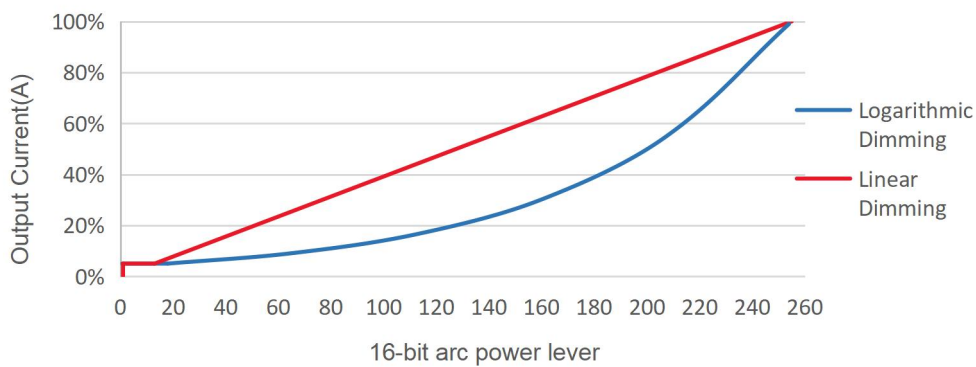

DALI-2 Dimming Curve

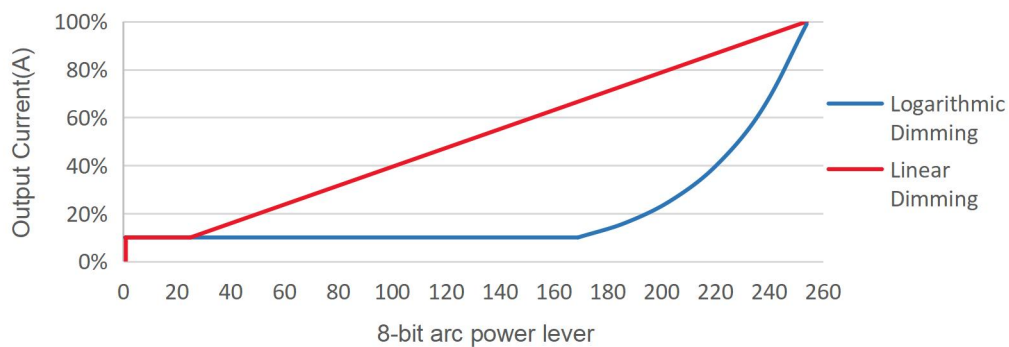

Note: Factory Default Output Logarithmic Curve.

Implementation:DMX512 Daisy chain

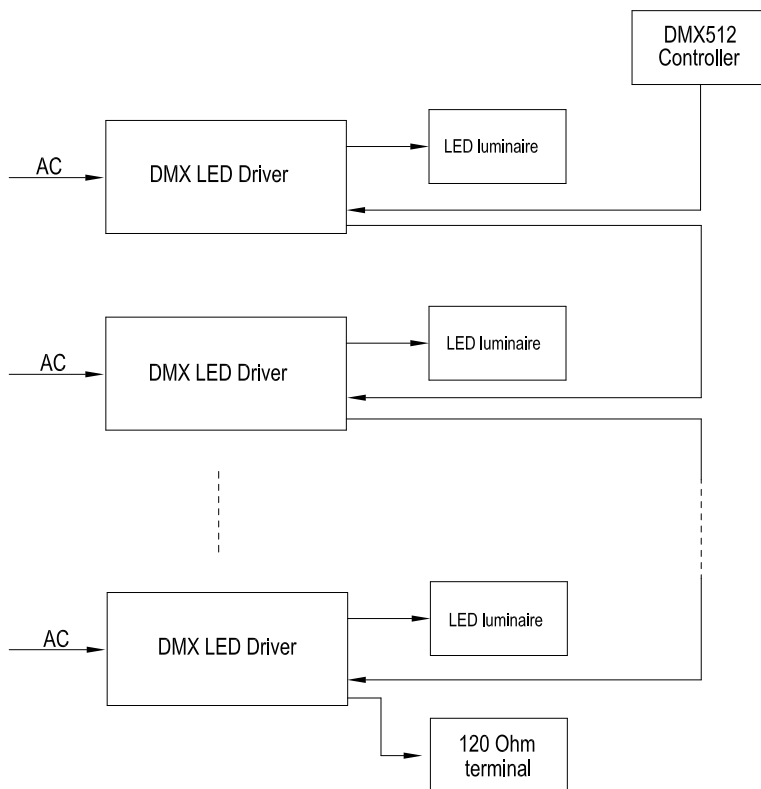

Note:

- [1]. Up to 64 drivers may be daisy-chained, terminated by a 120 Ohm resistor (connected between DMXA & DMXB as the last driver).
- [2]. 300m maximum length.
- [3]. 100m maximum between drivers.
- [4]. For best performance, a characteristic impedance of 120 Ohm should be maintained for the entire length of the control wire.

Programming Link (DMX&DALI-2)

■ For Dali

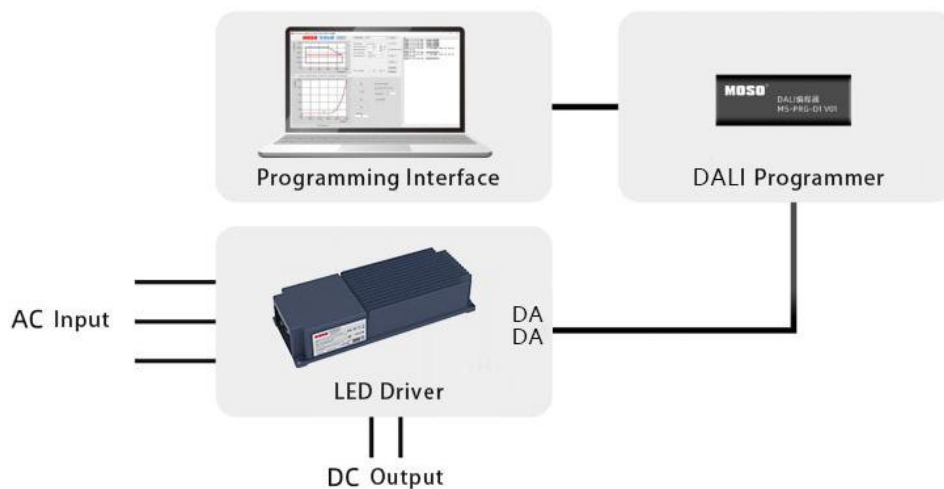

■ For DMX

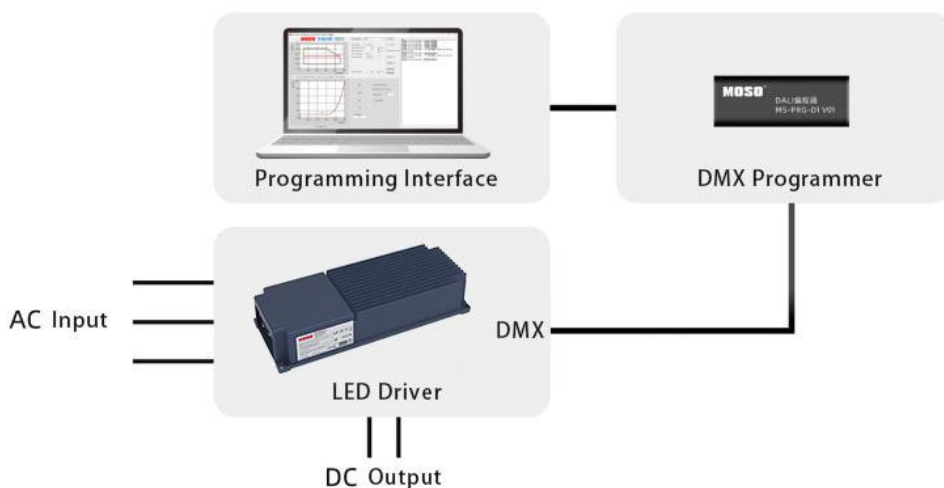

1. Dimming Mode Switching for DALI-2 & DMX-RDM

1.1 Switching from DALI-2 Dimming to DMX-RDM:

- a. After connecting the DMX programmer to computer, click on the software "Scan Port" button;
 - b. Click "Read Cfg" to import the corresponding model's DMX configuration file (Six .cfg files for S6-880W/1200W/1500W/1800W will be provided in advance by MOSO);
 - c. Click 'Set' button to transmit the .cfg file into the driver's MCU;
 - d. After setting and restarting the driver, the software interface displays the DMX dimming mode, indicating successful conversion;
- Note: If the third step fails to set, select "FFFFFFFFFFFF" for the Device UID and reset the driver.

1.2 Switching from DMX-RDM to DALI-2 Dimming:

- a. After connecting the DALI programmer to computer, click on the software "Scan Port" button;
- b. Click "Read Cfg" to import the corresponding model's DALI configuration file (Six .cfg files for S6-880W/1200W/1500W/1800W will be provided in advance by MOSO);
- c. Click 'Set' button to transmit the .cfg file into the driver's MCU;
- d. After setting and restarting the driver, the software interface displays the DALI-2 dimming mode, indicating successful conversion;

2. Operating instructions

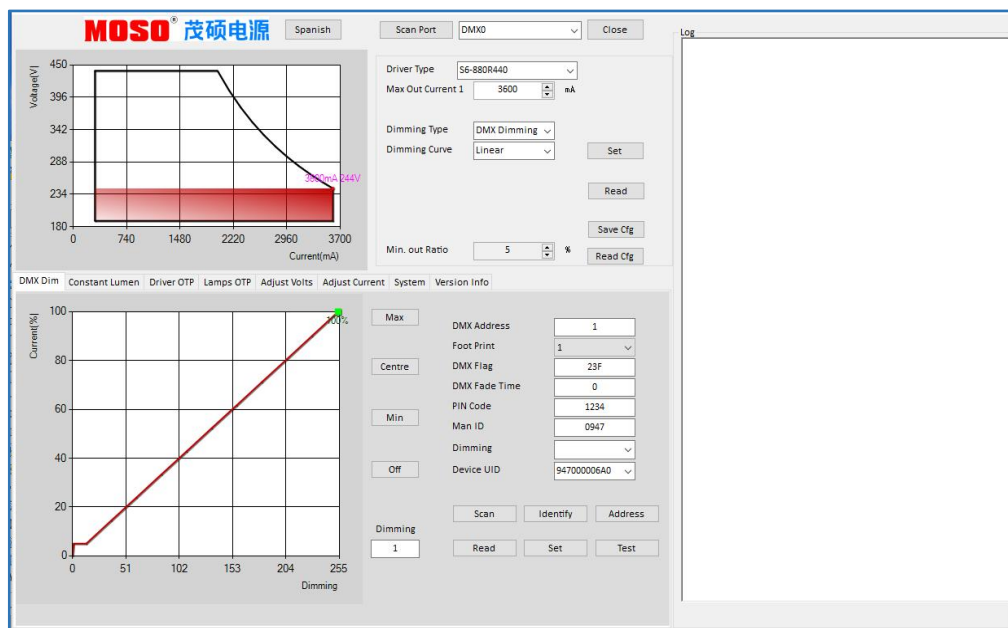

DALI / DMX visual software programming

1. Use corresponding programmer to connect with driver.
2. The output current of the two channels is independent. When setting the current, each channel needs to be modified.
3. The current parameters and configured driving parameters can be read and set.
4. Time dimming. Set the timing control function, which supports 7 segments.
5. Driver OTP and Lamps OTP. The Driver OTP and Lamps OTP parameters can be set according to the needs of customers.

3. NTC

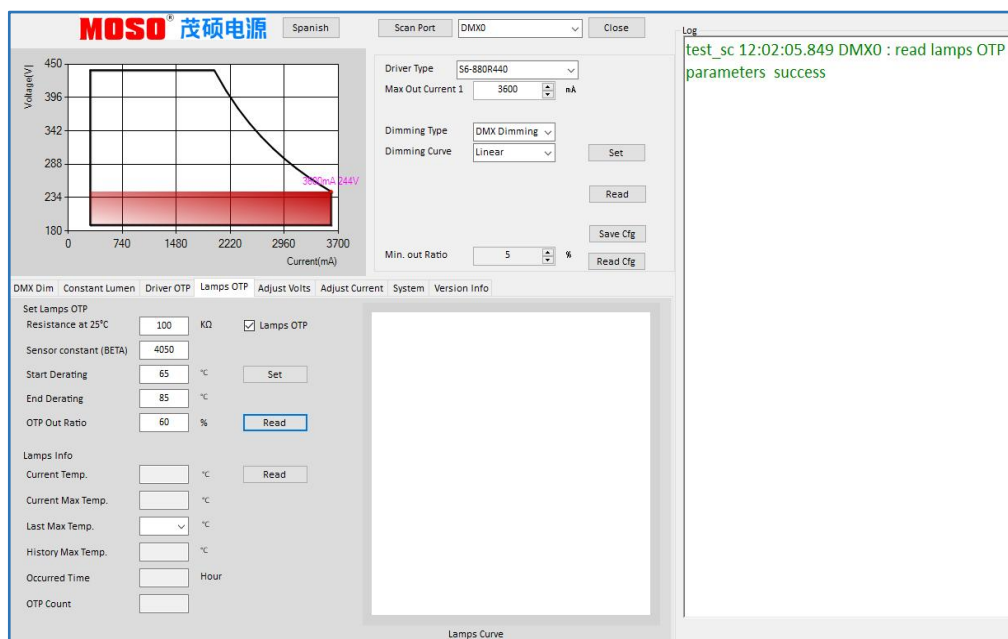

The recommended value of NTC resistance is 100KΩ, BETA: 4050

NTC resistance value changes with temperature:

4. DMX interface parameters

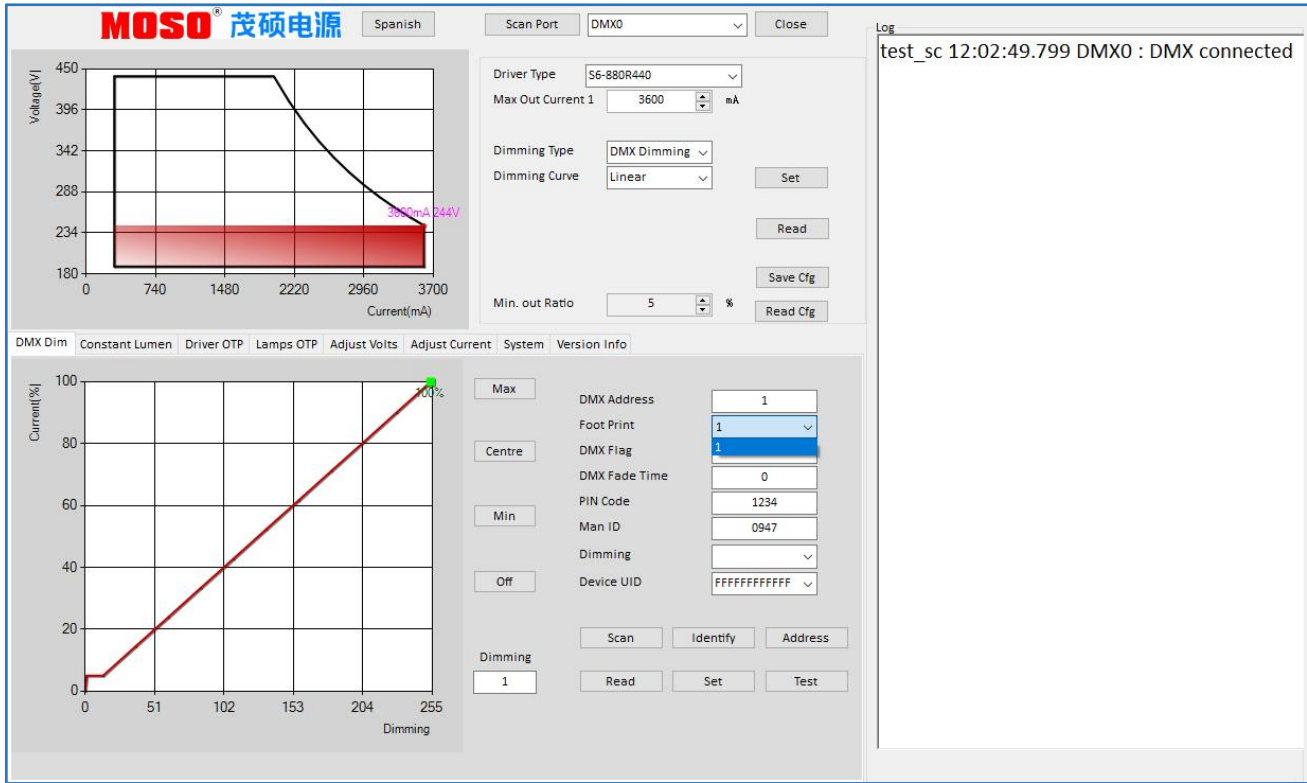

◆ **Scan**

When the DMX control system is connected to a new driver, customer need to click the “Scan” button to scan the new driver. The Configurer Tool will automatically read the Device UID of the newly connected driver in the system, The UID of the driver is displayed on the right LOG page. When the Device UID displayed by the Configurer Tool is consistent with the actual device UID of the driver, you can perform the next operation on the DMX driver, otherwise the software will display “read basic parameter fail”.

◆ **Identify**

The specific position of the driver can be identified by this function. Click the “Identify” button, and the light connected to the corresponding driver will flash to indicate its location.

◆ **Foot print**

This function is used to assign the number of addresses. For the S6-880Y440, since its output is only one channel, the default is 1.

◆ **Address**

The number of driver channels is equal to the number of DMX addresses occupied by the driver. For the S6-880Y440, since its output is only one channel, the address window displays the address of the channel.

⚠ Note: So for multichannel DMX drivers, the maximum configurable address equals : 512- (number of channels) +1, Unlike the “Address” button, which can only modify the DMX address of the driver, “Set” can set all the DMX parameter modified by customer into the driver.

◆ **DMX Flag**

The software displays the hexadecimal code and converts the corresponding binary code to correspond to functions. 1 indicates that the function is enabled and 0 indicates that the function is disabled. At present, only ten functions are supported.

For example, 23F=10 ,0011 ,1111 indicates that functions 0~5 and 9 are enabled.

◆ **Dimming**

This function is used to read the dimmer value data of the driver in real time and return the value.

◆ **DMX fade time**

The Fade Time will be started when the system changes the dimming value. The maximum of Fade Time for each steps can reach 2500ms, The calculation method is set value multiplied by 10ms.

The longest total time spent will be 635 seconds when dimming value has changed from 0 to 254 with maximum Fade Time. The calculation formula is as follows:

$$255 \text{ steps (whole dimming value has changed)} * 2500 \text{ms (maximum fade time)} \div 1000 \text{ (Unit conversion: from microseconds to seconds)} = 635 \text{ seconds.}$$

◆ **PIN Code**

The password for each driver to join the customer’s control system.

◆ **Device UID**

A window used to select the device UID of the driver. Use the “Scan” button to automatically switch the device UID of the driver newly connected to the system, or manually select the device UID previously connected.

Mechanical Outline

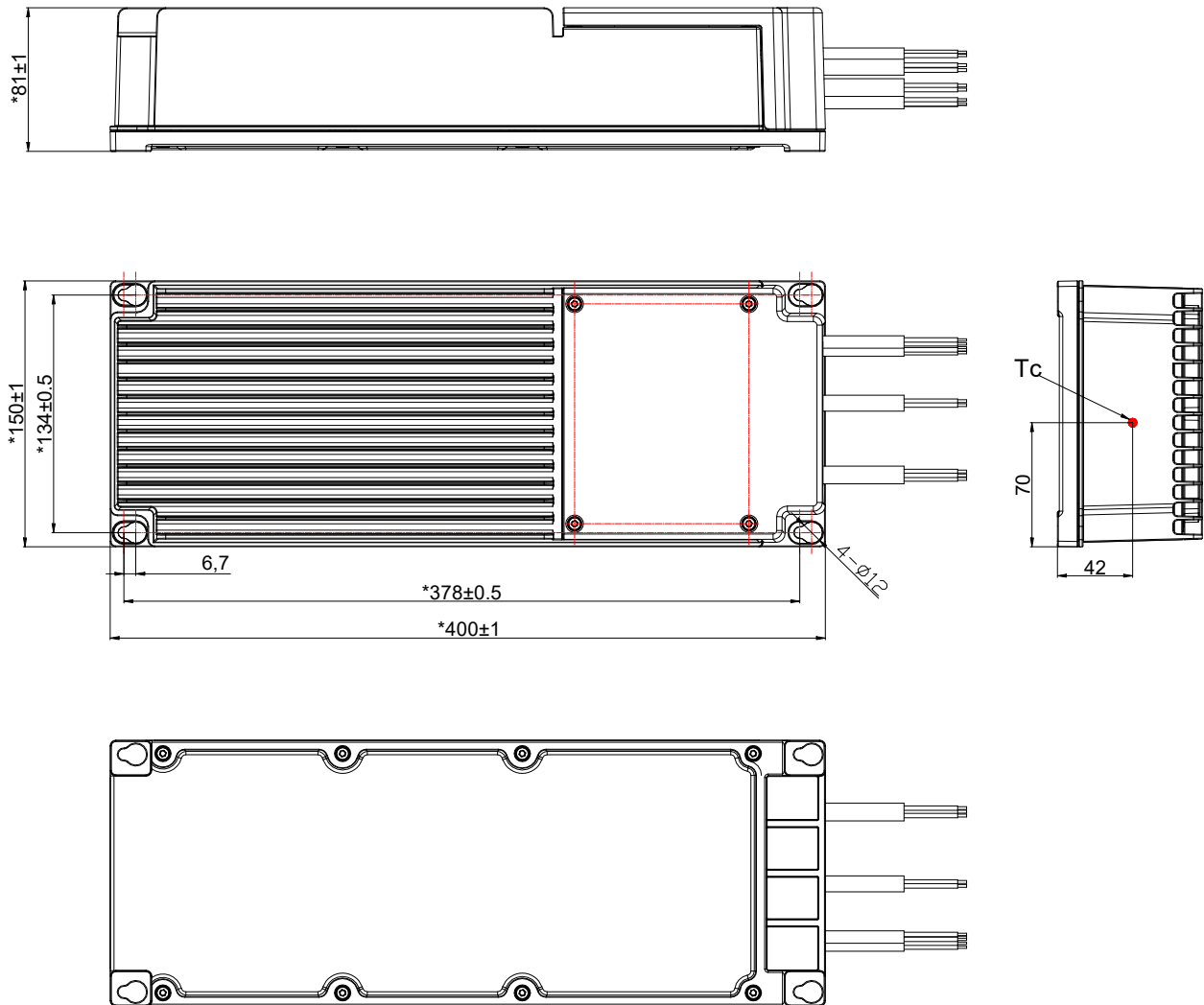

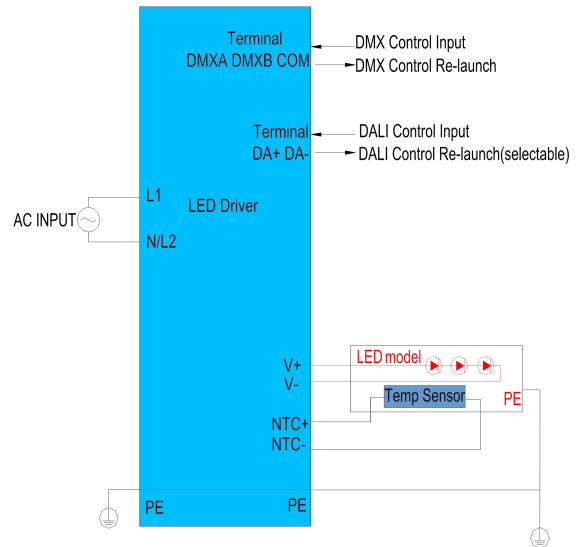
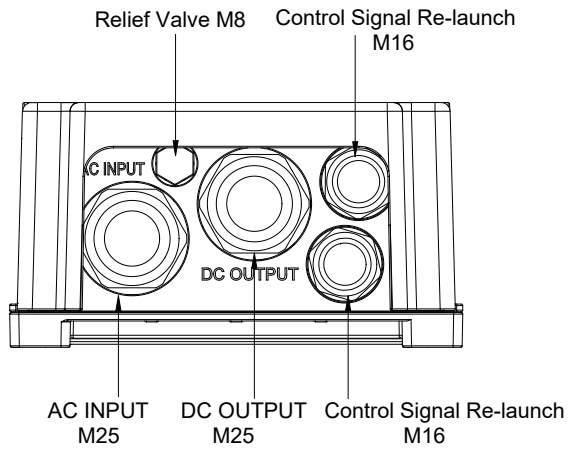

Wire Ports

Diagram

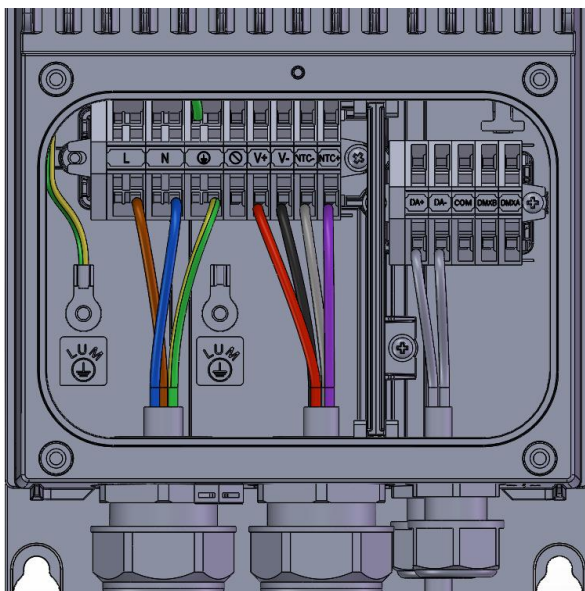

DALI Wiring Connection

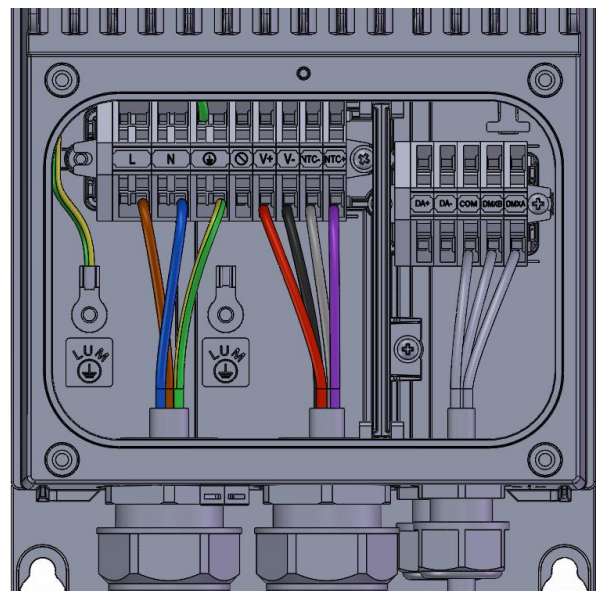

DMX Wiring Connection

Connections

Wire	Recommended wire Specification	Note
Input	M25 wire diameter range 9-16mm, optional for 13-18 mm ; Wire Cross-section: 1.0mm ² -4.0 mm ² /16AWG-12AWG	
Output,NTC	M25 wire diameter range 9-16mm, optional for 13-18 mm ; Wire Cross-section: 1.0mm ² -4.0 mm ² /16AWG-12AWG	
Dimming (DALI / DMX)	M16 wire diameter range 4-8mm, optional for 2-6mm Wire Cross-section: 0.5 mm ² -1.5 mm ² /22AWG-16AWG	
Dimming (DALI / DMX Re-launch)	M16 wire diameter range 4-8mm, optional for 2-6mm Wire Cross-section: 0.5 mm ² -1.5 mm ² /22AWG-16AWG	

Terminal	Recommended wire Specification	Note
Input	M25, the torsion 5~6N.m	
Output,NTC	M25, the torsion 5~6N.m	
Dimming (DALI / DMX)	M16, the torsion 1~2N.m	
Dimming (DALI / DMX Re-launch)	M16, the torsion 1~2N.m	

Label

DALI-2

S6-880D440
LED DRIVER(LED控制装置)
Constant current type(恒流模式)
Integrated SPD(内置防雷管)

INPUT 输入	220-400V~ 50/60Hz, 4.5A Max. PF:0.9C-0.98, 950W
OUTPUT 输出	Output: 190-440V=== 0.36-3.60A Max.Uout(最大电压): 530V=== Max.Power(最大功率): 880W
t _c : 90°C	t _a : 50°C

深圳茂硕电子科技有限公司/深圳市南山区西丽松白路1061号
SHENZHEN MOSO ELECTRONICS TECHNOLOGY CO., LTD
No.1061, Songbai Road, Xili Town, Nanshan District,
Shenzhen, CHINA
MADE IN CHINA
For LED module only

Input
Output
Dimming

DMX512

S6-880R440
LED DRIVER(LED控制装置)
Constant current type(恒流模式)
Integrated SPD(内置防雷管)

INPUT 输入	220-400V~ 50/60Hz, 4.5A Max. PF:0.9C-0.98, 950W
OUTPUT 输出	Output: 190-440V=== 0.36-3.60A Max.Uout(最大电压): 530V=== Max.Power(最大功率): 880W
t _c : 90°C	t _a : 50°C

深圳茂硕电子科技有限公司/深圳市南山区西丽松白路1061号
SHENZHEN MOSO ELECTRONICS TECHNOLOGY CO., LTD
No.1061, Songbai Road, Xili Town, Nanshan District,
Shenzhen, CHINA
MADE IN CHINA
For LED module only

Input
Output
Dimming

Note:

The accessory package includes label of S6-880R440*1; Allen key(H3)*1; O-ring(13~18mm)*2; O-ring(2~6mm)*2

Cautions Label

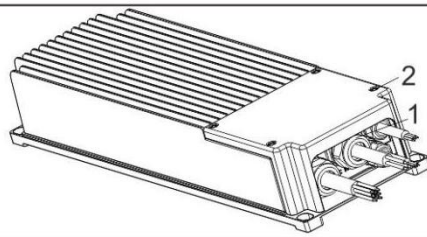

CAUTIONS

1. After the wiring is connected according to the datasheet, ensure that the gland is effectively locked to prevent water from damaging the driver.
2. When closing the electrical cover after wiring, ensure that the four fixing screws effectively tightened to prevent water from damaging the driver.

Shipping Barcode Label Standard

2	2	1	2	1	2	1	0	5	7	0	1	A	1	0	0	0	1
Year	month	day	Part of production order number			Engineering level	REVISION RR	Production line number			Progressive Serial number						

Version

A.1	First release	2024-03-01
B.2	ECL202403046	2024-03-20
C.2	/	2024-06-27

Specification for Approval

Product Name: 880W Non-isolate LED Driver

Product Model: S6-880R440

Rev : C.2

Address: XiLiSongbai Road 1061, Nanshan District, Shenzhen City, Guangdong, China

Tel: 0755-27657000

FAX: 755-27657908

E-mail: info@mosopower.com

Web Site: http://www.mosopower.com

Prepared By	Checked By	Approved By

Specification for Approval

Product Name: 880W Non-isolate LED Driver

Product Model: S6-880R440

Rev : C.2

CUSTOMER AUTHORIZED SIGNATURE		
Tested By	Checked By	Approved By
(Company seal)Return one copy to MOSO with approved signature and company seal.		

Address:XiLiSongbai Road 1061, Nanshan District, Shenzhen City, Guangdong, China

Tel: 0755-27657000

FAX: 755-27657908

E-mail:info@mosopower.com

Web Site:http://www.mosopower.com

Prepared By	Checked By	Approved By