

Specification for Approval

Product Name: 160W High Bay driver
Product Model: MTP-160M054
MTP-160V054
Rev. E.2
Sample Date: -

CUSTOMER AUTHORIZED SIGNATURE		
Tested By	Checked By	Approved By
(Company seal)Return one copy to MOSO with approved signature and company seal.		

XiLi Songbai Road 1061, Nanshan
Address: District, Shenzhen City, Guangdong Province, P.R.China Post Code: 518108
TEL: 0755-27657000 FAX: 0755-27657908
E-mail: wcx@mosopower.com Web site: <http://www.mosopower.com>

Prepared By	Checked By	Approved By



ECN History

Rev.	Description of Change		Changed Date	Notes
	Before	After		
A.1	Original Release	---	2018-8-20	
B.2		ECR No:ECL201812105	2018-12-24	
C.2		ECR NO:ECL201812110	2018-12-25	
D.2		No:ECL201907015	2019-07-05	
E.2		No:ECL201908112	2019-08-26	



PRODUCT FEATURES

- Universal input voltage: 90~305Vac;
- Constant power design;
- (M types) Offline programming through dimming wire, (V types) Setting current with a built-in variable resistor;
- 2-in-1 dimming mode: 0-10Vdc, PWM dimming; Dim-to-off;
- Surge protection: 4KV line-line, 6KV line-earth;
- Multiple protection: SCP, Output OVP, Input UVP, OTP;
- IP65 design for indoor and outdoor applications;
- 5 years warranty.

APPLICATION

- Suitable for industrial lighting.

DESCRIPTION

MTP-160W series is specially designed for industrial lighting applications. It is constant power LED driver that operates from 90-305Vac with 0-10V and PWM dimming function. The output parameters are configurable by internal potentiometer or dimming wire within a wide range of DC Load. This round integrated structure enables it to have a better heat dissipation cooler, significantly improving reliability and extending product life. To ensure trouble free operation, protection is provided against input surge, output over voltage, short circuit, and over temperature.

MODELS

Model Number	Max Output Power (W)	Output Voltage Range (Vdc)	Output Current Adjustable Range (A)	Full Power Current Adjustable Range (A)	Default Output	Typical Efficiency [2]	Power Factor	
							120Vac	230Vac
MTP-160X054 ^[1]	160	38~54	2.10~3.80	2.96~3.80A	38~42V/3.80A	89%	0.99	0.97

Notes:

1. X=M, programming through dimming wire; X=V, output current adjustable through potentiometer;
2. All parameters not specially mentioned are measured at 230Vac input, full load and 25°C of ambient temperature.

OPERATING AREA I-V

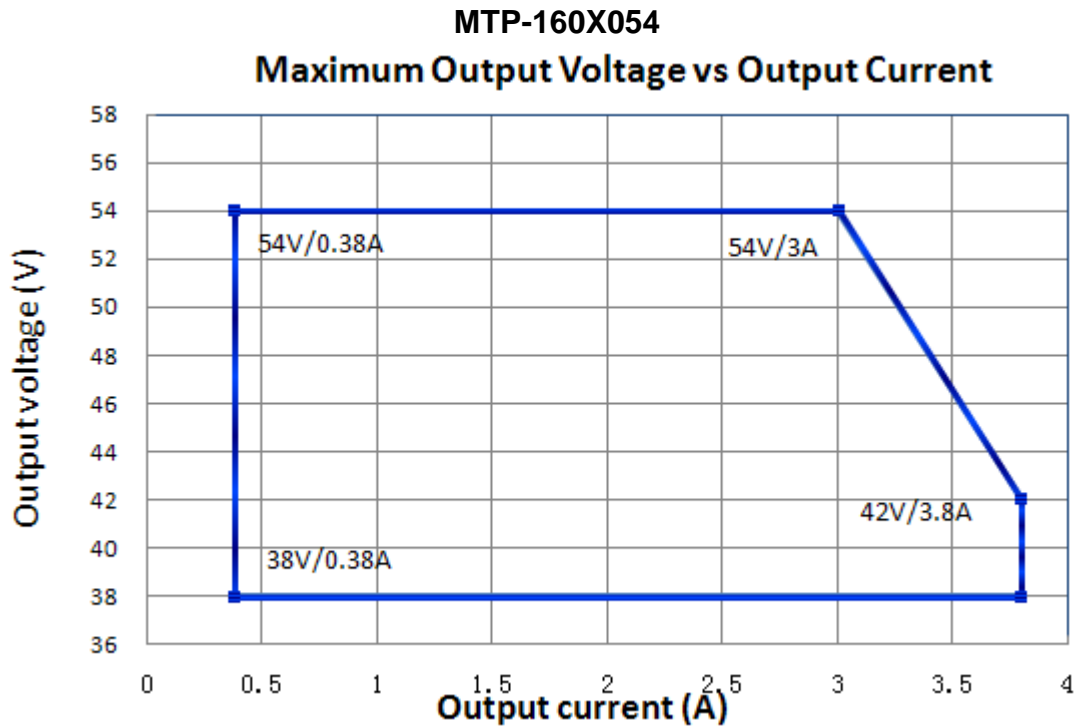

Note: X=V is suitable for the dotted line on the right side area; X=M is suitable for the solid line contain area.

INPUT SPECIFICATIONS

Parameter	Min.	Typ.	Max.	Notes
Input Voltage	90Vac	100-277Vac	305Vac	
Input Frequency	47Hz	50/60	63Hz	
Leakage Current	-	-	0.75mA	277Vac/60Hz
Input AC Current	-	-	2.2Amax	100-277Vac & full load
Inrush Current(A)	-	-	75A	230Vac & full load
Power Factor	0.95	0.97	-	230Vac & full load
THD	-	7%	10%	120~230Vac, 80%~100% load
	-	-	20%	277Vac, 70%~100% load

OUTPUT SPECIFICATIONS

Parameter	Min.	Typ.	Max.	Notes
Output Current Tolerance	-5%	-	5%	
Output Current Setting Range (A) MTP-160X054	2.10	-	3.80	(M types) Output Current Setting Range: 10%-100%I _{max}
Output Current Setting Range with Constant Power(A) MTP-160X054	2.96	-	3.80	
Total Output Current Ripple (pk-pk)	-	5%	10%	20MHz BW, load is LED, ripple is different with difference LED load.
Startup Overshoot Current	-	-	10%	120~277Vac & 100% Load, load is LED
No Load Output Voltage(V) MTP-160X054	-	-	70	
Line Regulation	-	-	1%	25°C±10°C ambient temperature, input voltage changes from 115Vac to 277Vac.
Load Regulation	-	-	3%	25°C±10°C ambient temperature, 230Vac input, load changes from 60% to 100%.
Turn-on Delay Time	-	-	3S	120Vac,100% load
	-	0.5S	1.5S	230Vac,100% load

GENERAL SPECIFICATIONS

Parameter	Min.	Typ.	Max.	Notes	
Efficiency@120Vac MTP-160X054 I _o =2.96 I _o =3.80	85% 84%	87% 86%	-	Measured at full load and 25°C ambient temperature, full load.	
Efficiency@230Vac MTP-160X054 I _o =2.96 I _o =3.80	87% 87%	89% 89%	-	Measured at full load and 25°C ambient temperature, full load.	
Efficiency@277Vac MTP-160X054 I _o =2.96 I _o =3.80	87% 87%	89% 89%	-	Measured at full load and 25°C ambient temperature, full load.	
Dielectric Strength	Input-Output	-	3750Vac	-	10mA/60S
	Input-PE	-	1600Vac	-	
	Output- PE	-	1600Vac	-	
Grounding Resistance	-	-	0.1Ω	25A/60S	
Insulation Resistance	50MΩ	-	-	Input-Output, Input-PE, Output-PE, 500Vdc/60S/25°C/70%RH	
MTBF	-	200000Hrs	-	230Vac,80% load (MIL-HDBK-217F)	
Lifetime	-	50000 Hrs	-	230Vac&100% load,70°C case temperature, refer to lifetime VS Tc curve for details	
Operating Case Temperature for Safety Tc _s	-40°C	-	+90°C		
Operating Case Temperature for Warranty Tc _w	-40°C	-	+70°C	5 years warranty Humidity: 10% to 95RH	
Storage Temperature	-40°C	-	+85°C	Humidity: 5% to 100% RH	
Dimensions (D×H)mm	Φ146X74.1				
Net Weight	1250±100g/PCS				
Package	L460*W390*H200mm; 8PCS/Ctn.				

DIMMING

Parameter	Min.	Typ.	Max.	Notes
0~10V Absolute Maximum Voltage on the Vdim (+) Pin	-	10V	-	
0~10V Source Current on Vdim(+)Pin	-	1mA	2mA	
Dimming Output Range	MTP-160M054	10% I _{max}	-	I _{max} =3.80A
	MTP-160M054	0.38A	-	3.80A
Recommended Dimming Range for 0-10V	0V	-	10V	Default 0-10V/PWM dimming Dim-to-off
PWM_in High Level	9.7V	-	10.3V	
PWM_in Low Level	0V	-	0.3V	
PWM_in Frequency Range	200Hz	-	2KHz	
PWM_in Duty Cycle	10%	-	100%	

SAFTY STANDARDS

Safety Category	Country / Territory	Standards	Whether have Certification
CCC	China	GB19510.1, GB19510.14	√
CE	Europe	EN61347-1, EN61347-2-13	√
		EN62493	
CB	CB Countries	IEC61347-1, IEC61347-2-13	√
BIS	India	IS 15885(PART 2/SEC 13)	
UL	USA	UL 8750	√
CUL	Canada	CSA C22.2 No.250.13	√
KC	South Korea	K61347-1, K61347-2-13, K62384	
PSE	Japan	J61347-1, J61347-2-13	
SAA	Australia	AS/NZS IEC 61347.2.13	√
		AS/NZS 61347.1	√

EMC COMPLIANCE

EMC Category	Country / Territory	Standards	Whether have Certification
CCC	China	GB/T 17743, GB 17625.1	√
CE	Europe	EN 55015	√
		EN 61000-3-2, EN 61000-3-3	√
		EN61000-4-2,3,4,5,6,8,11	√
		EN 61547	√
KC	South Korea	K61547	
		K00015	
PSE	Japan	J55015	
FCC	USA	FCC part 15	

NOTE:

This LED driver meets the EMI specifications above, but EMI performance of a luminaire that contains it depends also on the other devices connected to the driver and on the fixture itself.

INRUSH CURRENT WAVEFORM

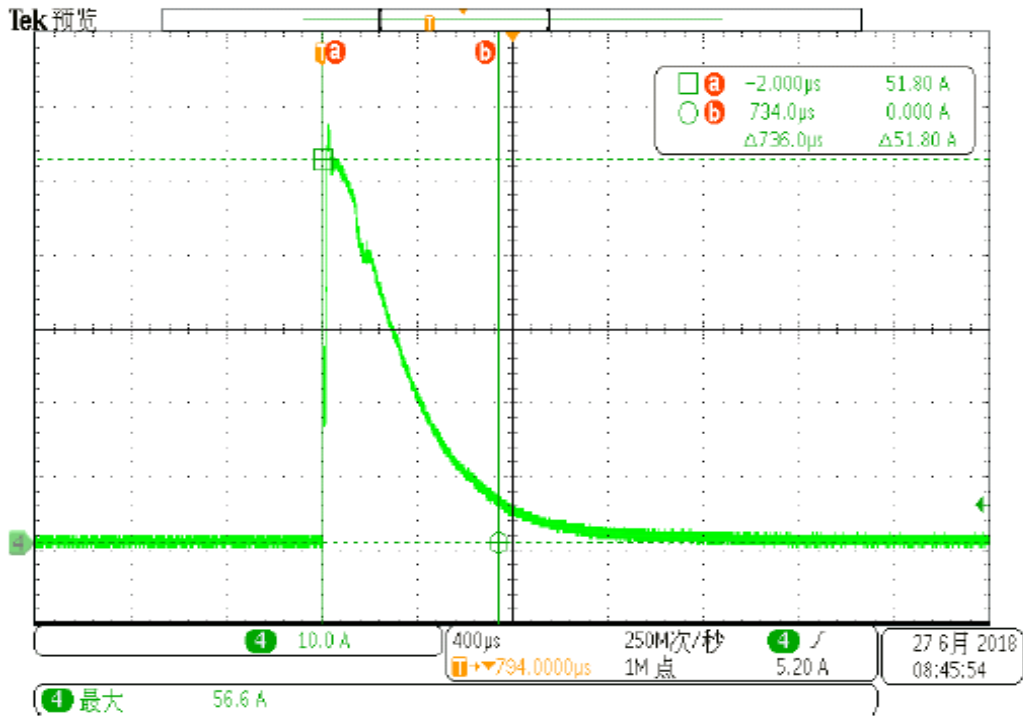

DERATING CURVE

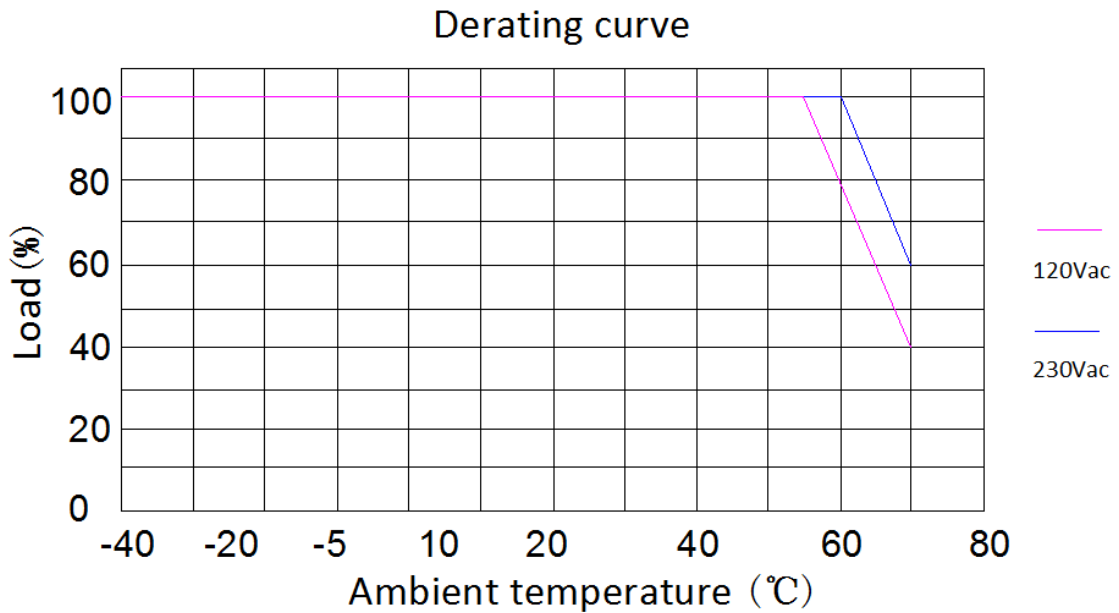

OUTPUT POWER VS INPUT VOLTAGE

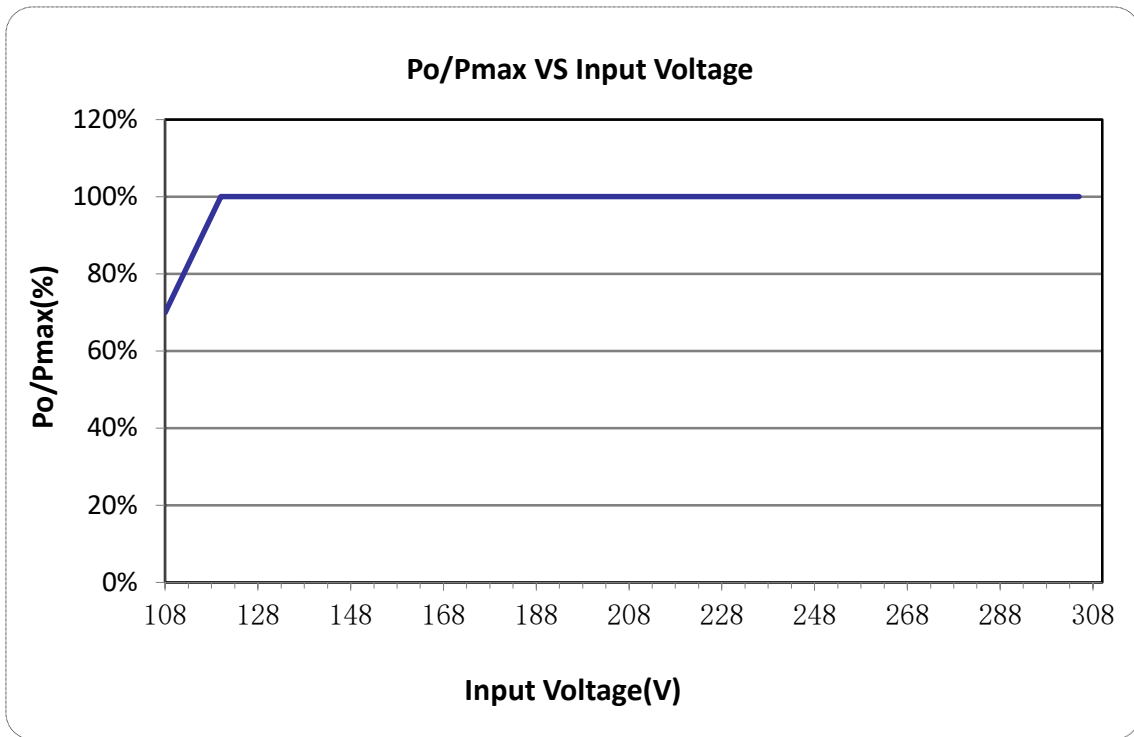

LIFETIME VS CASE TEMPERATURE

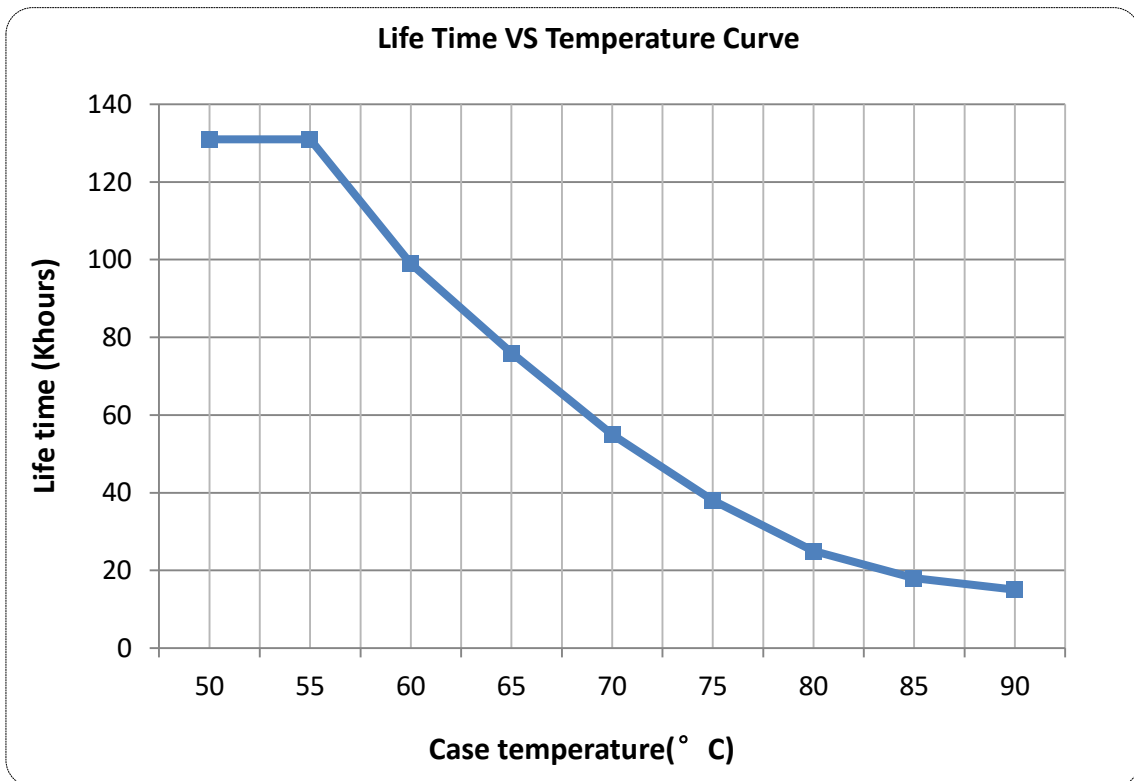

EFFICIENCY VS LOAD

Io=3.80A

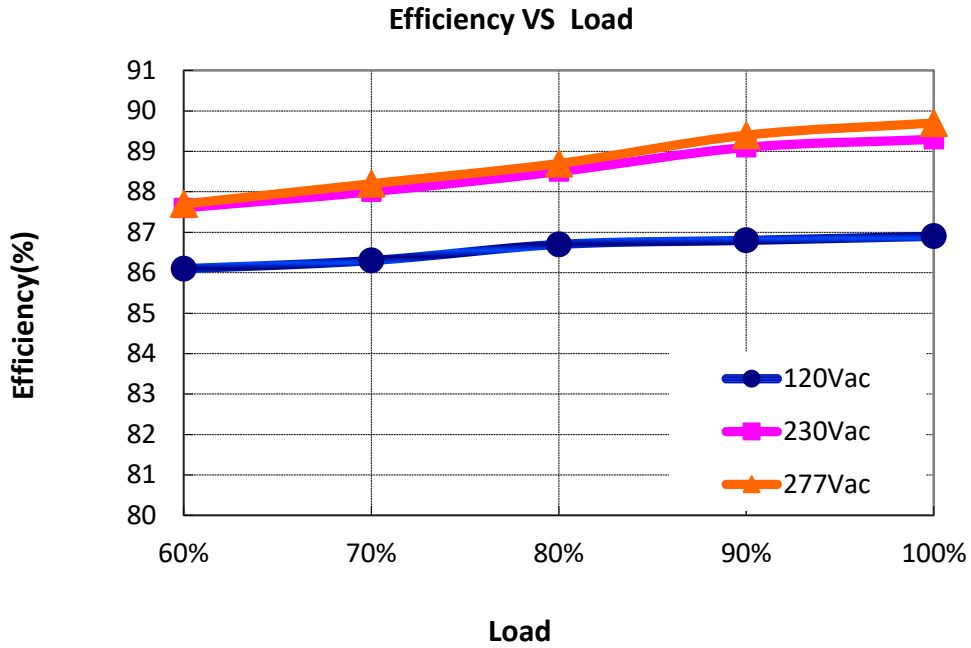

Io=2.96A

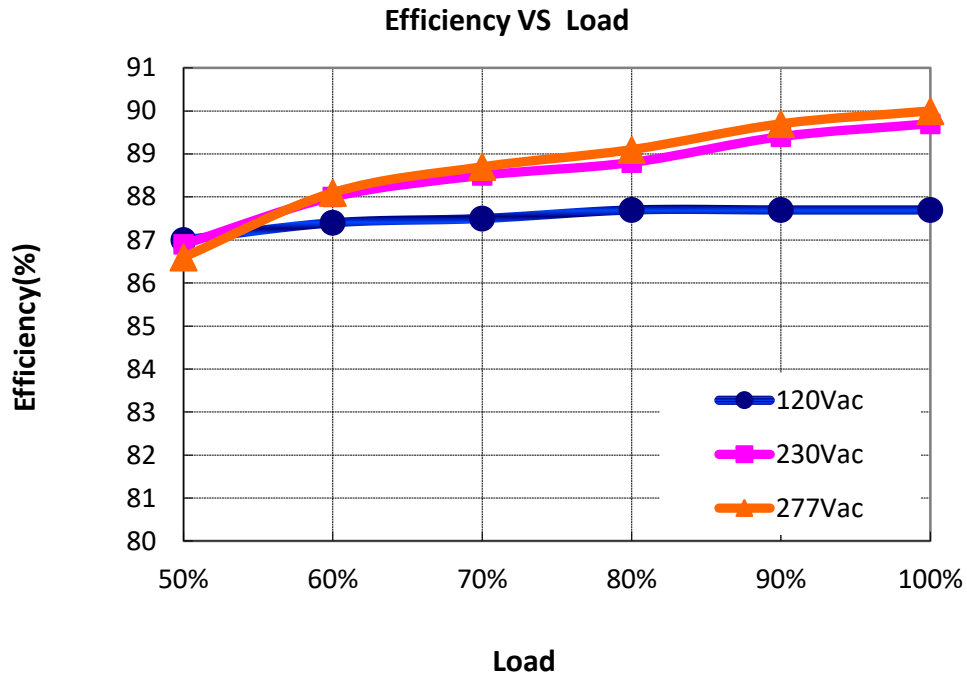

POWER FACTOR VS LOAD

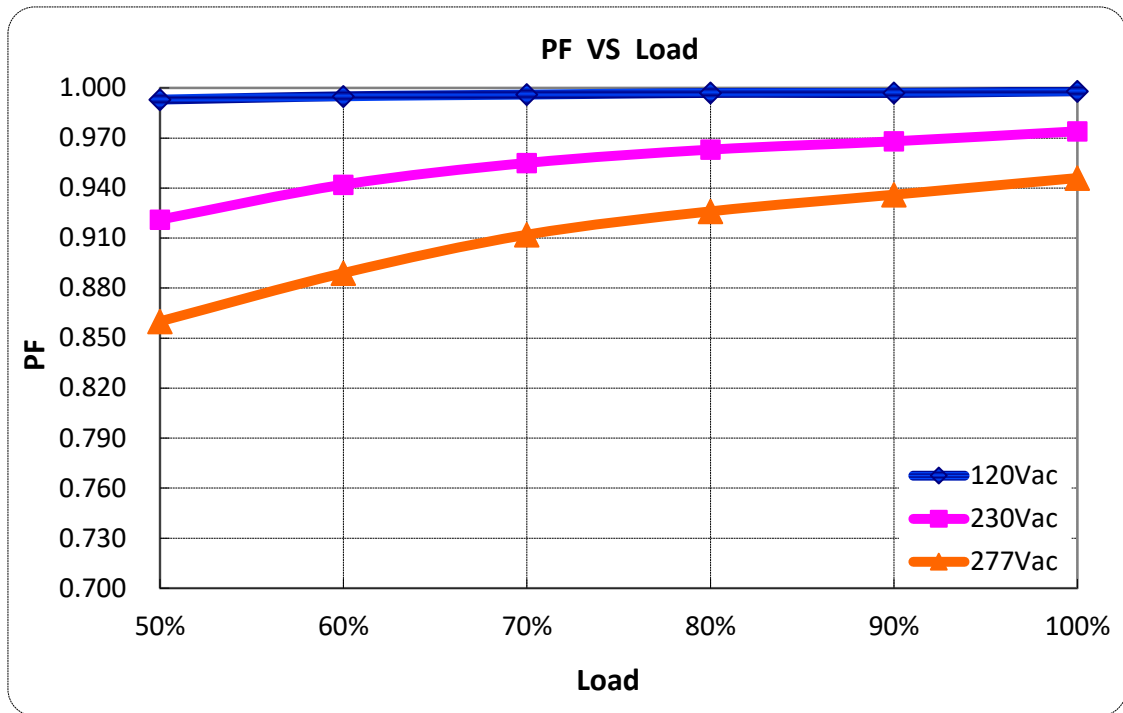

TOTAL HARMONIC DISTORTION

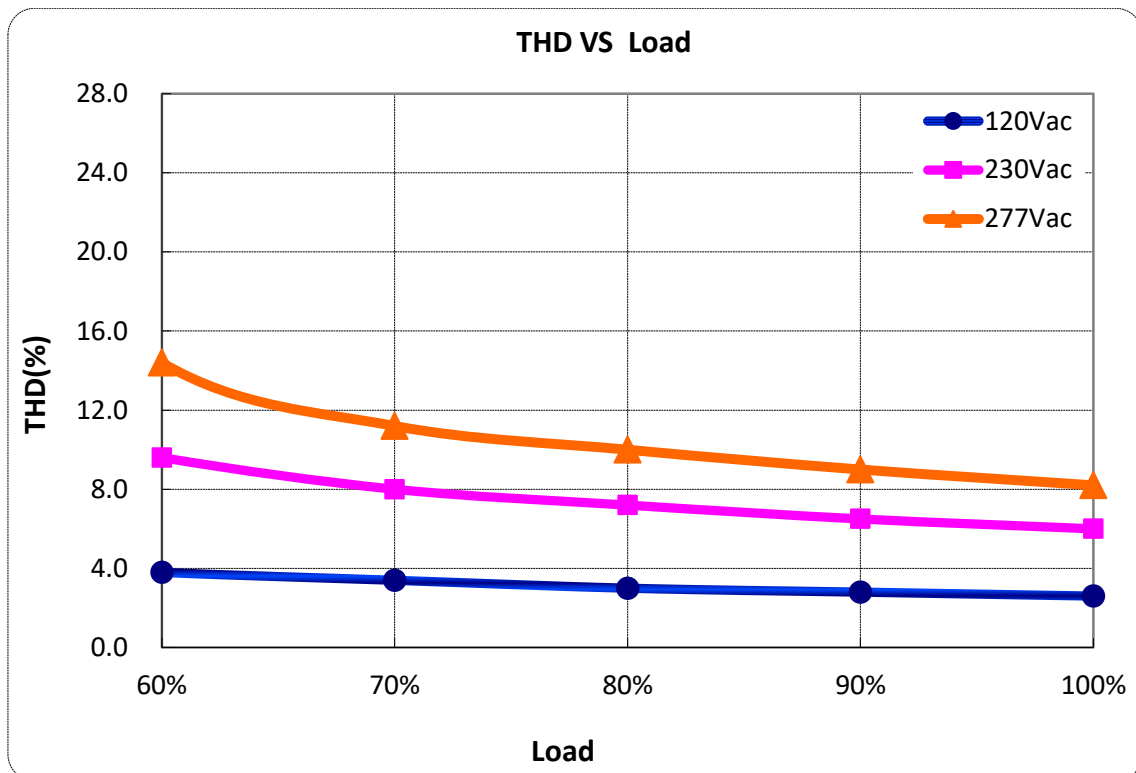

0-10V/PWM DIMMING CURVE

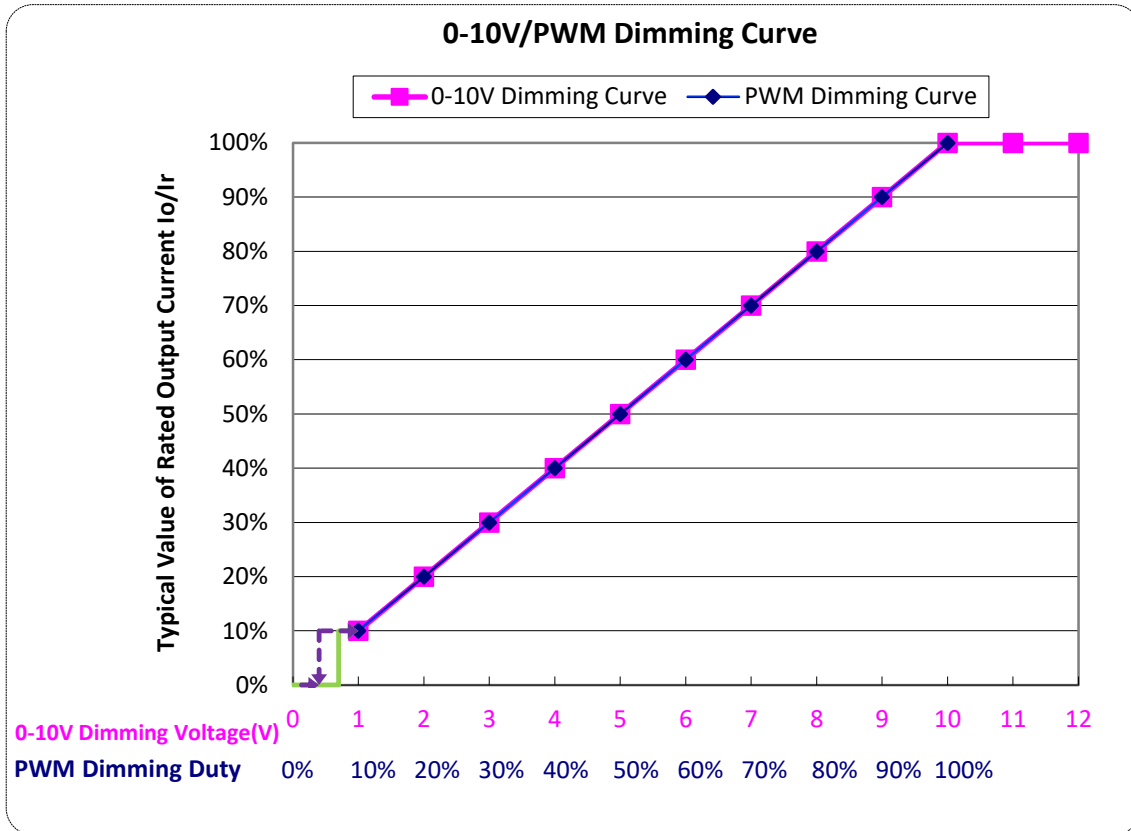

PROTECTIONS

Parameter	Notes
Over Temperature Protection	Decreases output current, returning to normal after over temperature is removed..
Short Circuit Protection	Hiccup mode and auto recovery. No damage will occur when any output is short circuited. The output shall return to normal when the fault condition is removed.
Over Voltage Protection	Run into protection model when output voltage exceeds limit, and return to normal when the fault.

MECHANICAL OUTLINE

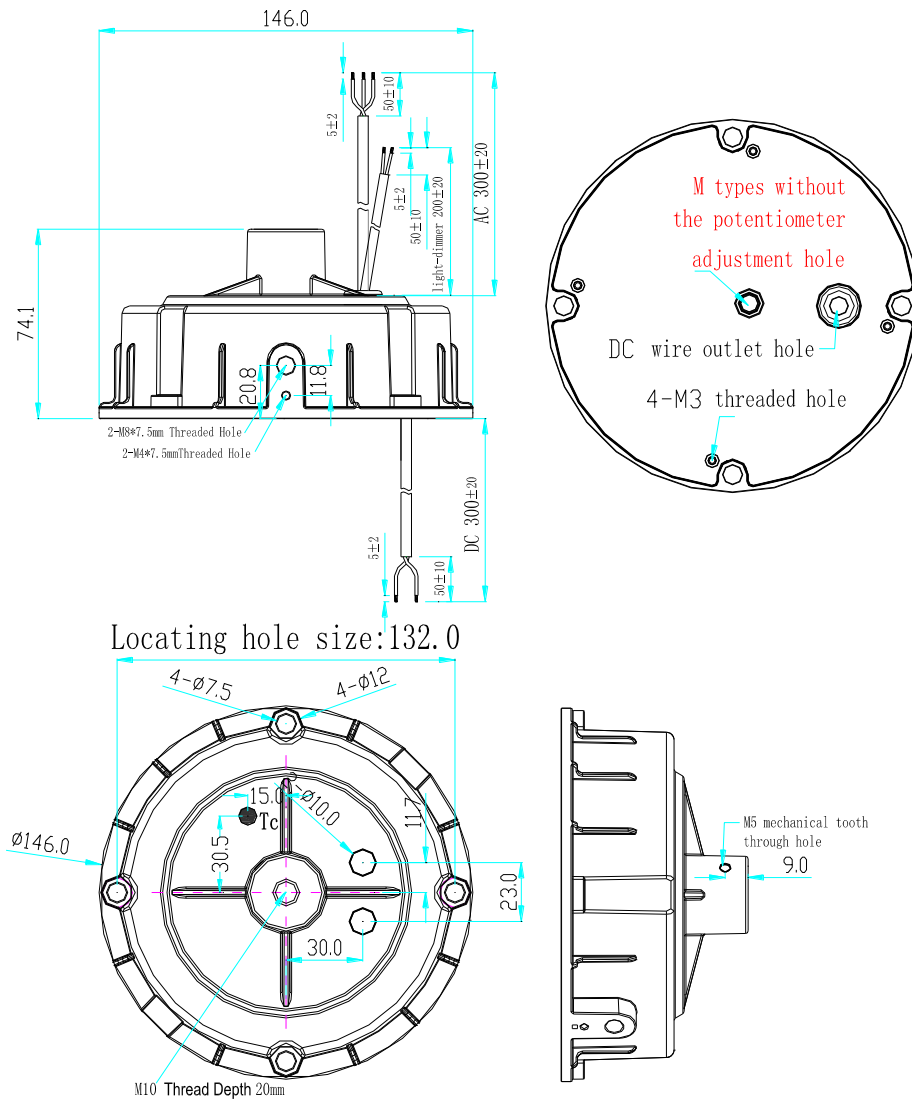

Note: Case color: RAL 9017 glossy black.

Wire	Specification	Note
Input	CCC+VDE H05RN-F 3x1.0mm ² OD=7.3mm L=300±20mm L:Brown, N:Blue, G:Yellow/Green	CCC/CE
	SJOW 18AWG*3C OD=7.8mm L=300±20mm L:Black, N:White, G:Green	UL
Output	CCC+VDE H05RN-F 2x1.0mm ² OD=7.0mm L=300±20mm LED+:Brown, LED-:Blue	CCC/CE
	SJOW 18AWG*2C OD=7.3mm L=300±20mm LED+:Red, LED-: Black	UL
Dimming	UL2733 22AWG*2C OD=5.45mm L=200±20mm DIM+:Purple, DIM-:Gray	X=M

Note: X=V with no dimming.

Product Specification

Product Name: 160W High Bay LED driver

Product Model: MTP-160M054
MTP-160V054

Rev. E.2

XiLi Songbai Road 1061, Nanshan
Address: District, Shenzhen City, Guangdong Province, P.R.China Post Code: 518108
TEL: 0755-27657000 FAX: 0755-27657908
E-mail: wcx@mosopower.com Web site: <http://www.mosopower.com>

Prepared By	Checked By	Approved By